

5. "CURVES"

* "A curve may be circular, parabolic or spiral and is always tangential to the two straight directions is called a curve."

* Types of curves :- Curves are divided into ~~three~~ ^{four} types.

1. Simple
2. compound and
3. Reverse.
4. Transition curve.

* Simple curve :- A curve is the one which consists of a single arc of a circle. it is tangential to both the straight line.

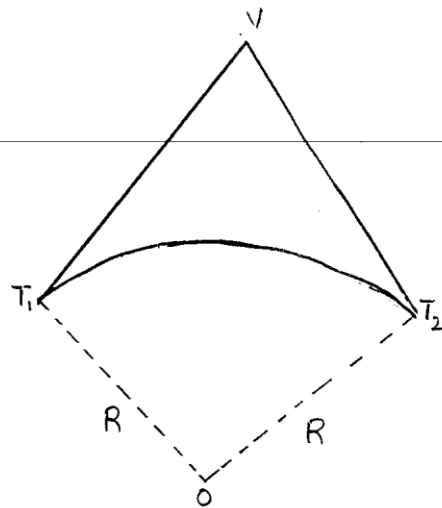

* Compound curve :- A compound curve ^{(a) Simple curve} consists of two or more simple arcs that turn in the same direction and join at common tangent points.

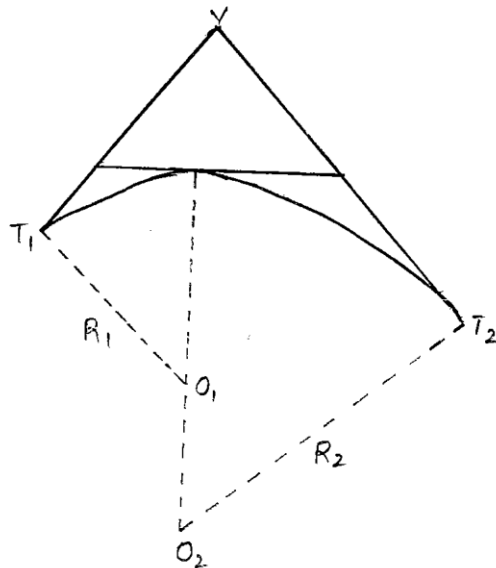

* Reverse curve :- A reverse curve is the one which consists of two circular arcs of same or different radii, having their centres to the different sides of the common tangent. Both the arcs thus bend in different directions with a common tangent at their junction.

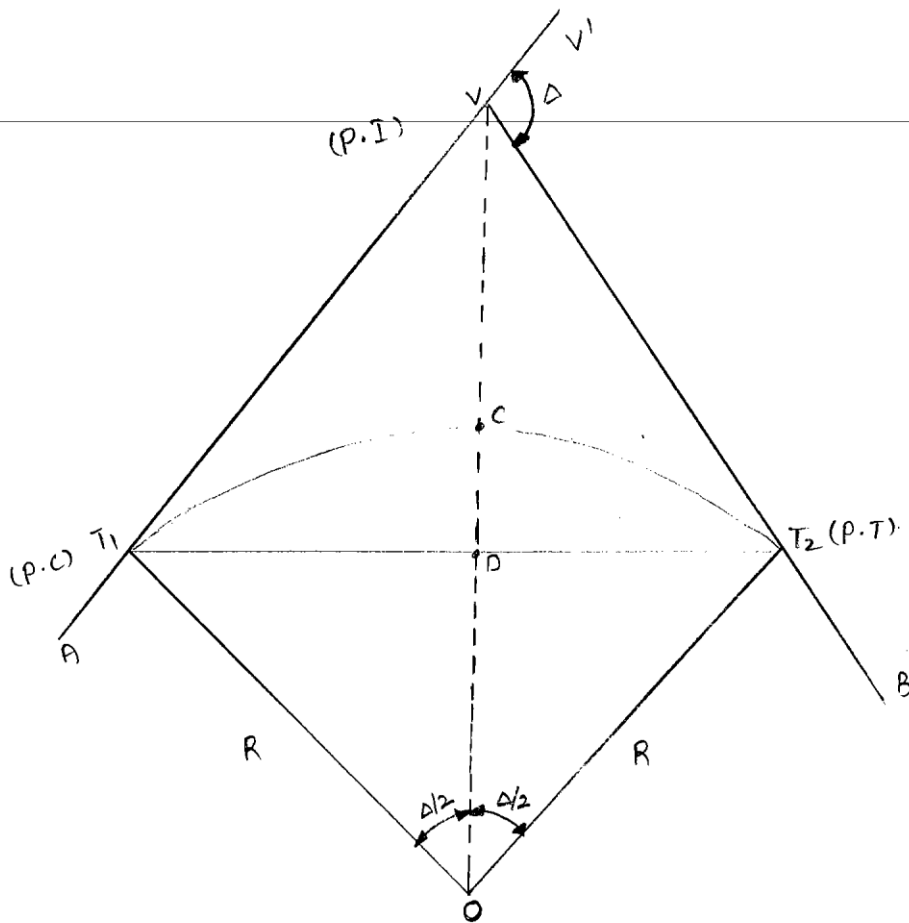
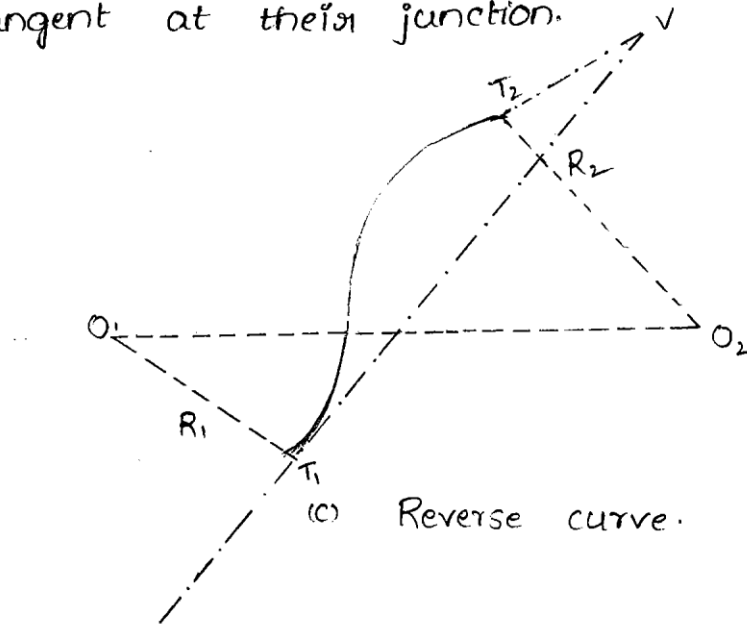

PARTS OF A CIRCULAR CURVE

- * Back tangent:- The tangent (AT_1) previous to the curve is called the back tangent (or) first tangent.
- * Forward tangent:- The tangent (T_2B) following the curve is called the forward tangent (or) second tangent.
- * point of intersection:- If the two tangents AT_1 and BT_2 are produced, they will meet in a point, called the point of intersection (P.I) or vertex (V).
- * point of curve:- It is the beginning of the curve where the alignment changes from a tangent to a curve.
- * point of tangency:- It is end of the curve where the alignment changes from a curve to tangent.
- * Intersection angle:- The angle $\angle V$ between the tangent AV produced and VB is called the intersection angle (A) or the external deflection angle between the two tangents.
- * Deflection angle to any points- The deflection angle to any point on the curve is the angle at P.C between the back tangent and the chord from P.C to point on the curve.
- * Tangent distance:- (T) It is the distance between P.C to P.I [also the distance from P.I to P.T].
- * External distance:- (E): It is the distance from the mid-point of the curve to P-I.
- * Length of curve:- (L) It is the total length of the curve from P.C to P.T.
- * Long chord :- It is chord joining P.C to P.T.
- * Mid - Ordinate:- (M):- It is the ordinate from the mid-point of the long chord to the mid-point of the curve.
- * Normal chord:- A chord between two successive regular stations on a curve.
- * Sub-chord:- (C) Sub-chord is any chord shorter than the normal chord.

- * Right-hand curve:- If the (chord) curve deflects to the right of the direction of the progress of survey, it is called the right-hand curve.
- * Left-hand curve:- If the curve deflects to the left of the (distance) direction of the progress of survey, it is called the left-hand curve.

* Designation of curve :-

The sharpness of the curve is designated either by its radius or by its "degree of curvature".

According to the arc definition, generally used in highway practice, The degree of the curve is defined as the central angle of the curve that is subtended by an arc of 100 ft length.

According to the chord definition, generally used in railway practice, the degree of the curve is defined as the central angle of the curve that is subtended by its chord of 100 ft length.

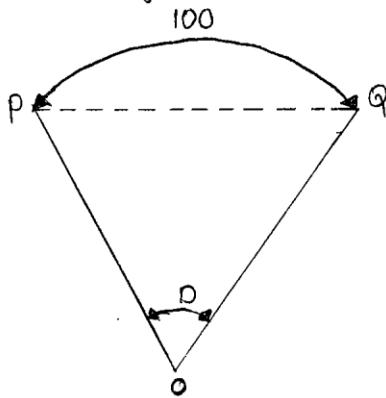

(a) Arc definition.

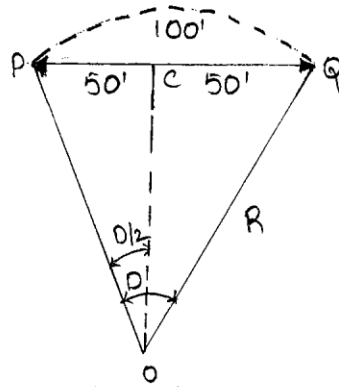

(b) Chord definition.

Arc definition :- we have,

$$100 : 2\pi R = D^\circ : 360^\circ$$

$$R = \frac{360^\circ}{D} \times \frac{100}{2\pi} = \frac{5729.578}{D} \text{ ft.}$$

Thus, radius of 1° curve is 5729.578 ft. To the first approximation, we have

$$R = \frac{5730}{D}$$

* Chord definition:- From $\Delta^{\text{le}} POC$ [Fig. b]

$$\sin \frac{1}{2} D = \frac{50}{R}$$

$$R = \frac{50}{\sin \frac{1}{2} D} \text{ (exact).}$$

When D is small, $\sin \frac{1}{2} D$ may be taken approximately equal to $\frac{1}{2} D$ radians.

$$R = \frac{50}{\frac{D}{2} \times \frac{\pi}{180}}, \text{ where } D \text{ is the degrees.}$$

$$= \frac{50 \times 360}{D \times \pi} = \frac{5729.578}{D} = \frac{5730}{D} \text{ (approximately).}$$

* Setting out Simple curves:-

The methods of setting out curves can be mainly divided into two heads depending upon instruments used:

1) Linear methods:- In the linear methods, only a chain or tape is used. Linear methods are used when

- a) A high degree of accuracy is not required.
- b) The curve is short.

2) Angular methods:- In the angular method, an instrument such as a theodolite is used with (or) without a chain (or) tape.

Before a curve is set out, it is essential to locate the tangents point of intersection (P.I), point of curve (P.C) and point of tangency (P.T).

* Linear methods of setting out:-

Following are some of the linear methods for setting out simple circular curves:

1. By ordinates or offsets from the long chord.
2. By successive bisection of arcs.
3. By offsets from the tangents.
4. By offsets from chords produced (or) by deflection distances.

* Compound curves:-

* Setting out compound curve:- The compound curve can be set by method of deflection angles. The first branch is set out by setting the theodolite at T_1 (P.C.) and the second branch is set out by setting the theodolite at the point D (P.C.C.). The procedure is as follows:

1) After having known any four parts, calculate the rest of the three parts by the formulae developed in § 2.2.

2) Knowing T_S and T_L , locate points T_1 and T_2 by linear measurements from point of intersection.

3) Calculate the length of curves L_S and L_L . Calculate the chainage of T_1 and T_2 as usual.

4) For the first curve, calculate the tangential angles etc., for setting out the curve by Rankine's method.

5) Set the theodolite at T_1 and set out the first branch of the curve as already explained.

6) After having located the last point D (P.C.C.) shift the theodolite to D and set it there. With the vernier set to $(360^\circ - \frac{\Delta_1}{2})$ reading, take a backsight on T_1 , on plunge the telescope. The line of sight is thus oriented along T_1D produced and if the theodolite is now swung through $\frac{\Delta_1}{2}$, the line of sight will be directed along the common tangent DD_2 . Thus the theodolite is correctly oriented at D.

7) Calculate the tangential angles of the second branch and set out the curve by observations from D, till T_2 is reached.

8) Check the observations by measuring the angle T_1DT_2 , which should be equal to $(180^\circ - \frac{\Delta_1 + \Delta_2}{2})$ or $(180^\circ - \frac{\Delta}{2})$.

* Geodetic Surveying :-

4

* The object of the geodetic surveying is to determine very precisely the relative or absolute positions on the earth's surface of a system of widely separated points.

* The relative positions are determined in terms of the lengths and azimuths of the lines joining them.

* The absolute positions are determined in terms of latitude, longitude and elevation above mean sea level.

* The distinction between geodetic surveying and plane surveying is fundamentally one of extent of area rather than of operation.

* The precise methods of geodesy are followed in the fieldwork of extensive plane trigonometrical surveys also.

* Since the area embraced by a geodetic survey forms an appreciable portion of the surface of the earth, the sphericity of the earth is taken into consideration while making the computation.

* Geodetic work is usually undertaken by the State Agency.

* Total Station :-

* A total station is a combination of an electronic theodolite and an electronic distance meter (EDM).

* This combination makes it possible to determine the co-ordinates of a reflector by aligning the instrument's cross-hairs on the reflector and simultaneously measuring the vertical and horizontal angles and slope distances.

* A micro-processor in the instrument takes care of recording readings and the necessary computations.

* The data is easily transferred to a computer where it can be used to generate a map.

* Wild Tachymat Tc 2000, described in the previous article is one such total station manufactured by M/s "Wild Heerbrugg".

* In the field, it requires team work, planning, and careful observations.

* The more the user understands how a total station works, the better they will be able to use it.

Fundamental measurements: When aimed at an approximate target a total station measures three parameters. See the Fig. a

1. The rotation of the instrument's optical axis from the instrument north in a horizontal plane: i.e., Horizontal angle.
2. The inclination of the optical axis from the local vertical i.e., Vertical angle.

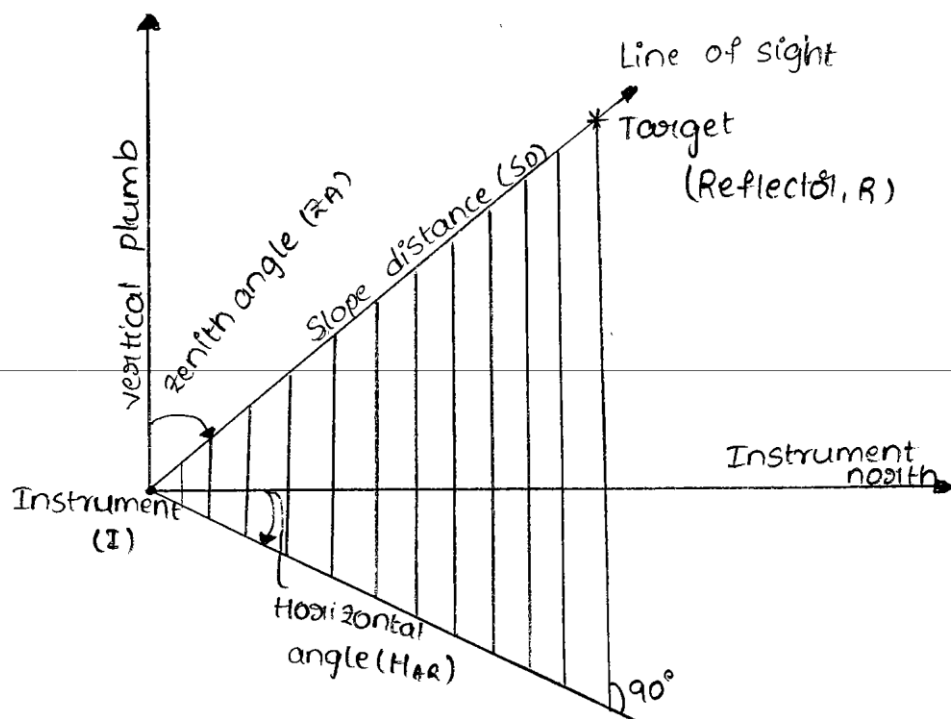

Fig. (a)

Fundamental measurements made by a Total Station.

3. The distance between the instrument and the target i.e., slope distance.

All the numbers that may be provided by the total station are derived from these fundamental measurements.

* Global positioning System :- (GPS)

* SR9400 GPS Sensor :-

New possibilities for single-frequency GPS :-

The high-accuracy carrier phase and ultra-precise code measurements, the SR9400 opens up many new possibilities for single-frequency surveying:

1. Control, detail, topographic and engineering surveys to centimeter accuracies with differential phase.
2. GIS, mapping, seismic and hydrographic surveys with sub-half meter positioning with differential code.
3. Data recording and post processing.
4. Real-time GPS surveying.

* Cost Effective to GPS cost-effective solutions :-

GPS has attractive price and versatility, the SR9400 provides easy entry to GPS surveying and cost effective solutions for many tasks:

* Control surveys with short and medium lines, when very short observation times are not essential and the influence of the ionosphere is relatively small.

* Kinematic surveys.

* Real-time surveys.

* SR9400 GPS Sensor with a TAO1 Antenna :-

1. code (pseudorange) measurements of remarkably high precision for 30-50 cm differential positioning.

2. High-accuracy, carrier-phase measurements for centimeter level work.

3. Highest-possible signal strengths for reliable satellite tracking to low elevations and under poor conditions.

For DGPS applications, RTCM V2.0 output and input are available via the CR344 controller, reference-station software and SPCS software; NMEA sentences can be output.

* Functioning of Gps controllers:-

The SR9400 connects to the CR333 and CR344 controllers. All the features, functions and operations of System 300 are provided.

* Real-time Gps Surveying:-

When connected to a CR344 controller and radio modem, the SR9400 can be used very effectively for real-time surveying and setting out. Depending on the mode, achievable in real time are:

* 10-20mm + 2ppm with differential phase.

* 30-50cm with differential code.

* By ordinates from the long chord :-

Let R = Radius of the curve

O_0 = Mid-ordinate

O_x = Ordinate at distance 'x' from the mid-point of the chord.

T_1 and T_2 = Tangent points.

L = Length of the long chord actually measured on the ground.

Bisect the long chord at point D .

from $\Delta^{1e} OT_1D$

$$OT_1^2 = T_1D^2 + DO^2$$

$$R^2 = \left(\frac{L}{2}\right)^2 + (CO - CD)^2 = \left(\frac{L}{2}\right)^2 + (R - O_0)^2.$$

$$(R - O_0) = \sqrt{R^2 - \left(\frac{L}{2}\right)^2} \quad (or)$$

$$O_0 = R - \sqrt{R^2 - \left(\frac{L}{2}\right)^2}.$$

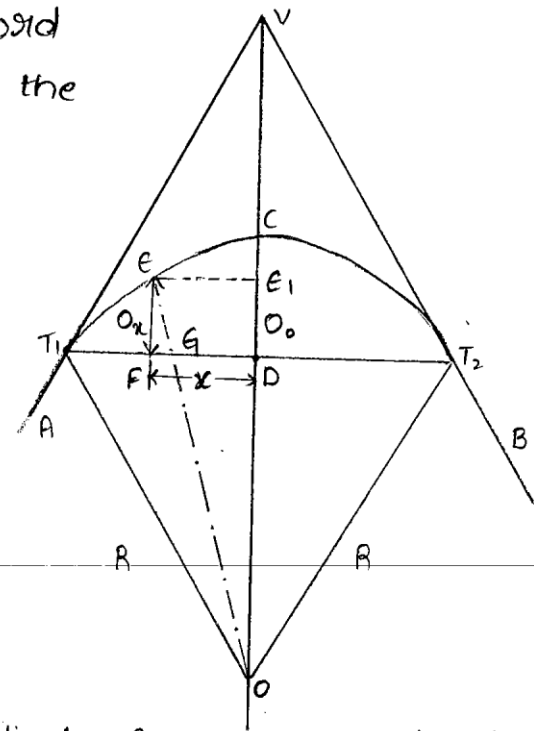

In order to calculate the ordinate O_x to any point E , draw the line EE_1 parallel to the long chord T_1T_2 . join EO to cut the long chord in F .

Then $O_x = EF = E_1D$
 $= E_1D - DO$

$$= \sqrt{(EO)^2 - (EE_1)^2} = (CO - CD)$$

$$= \sqrt{R^2 - x^2} - (R - O_0) \rightarrow \text{Exact.}$$

The long chord is divided into an even number of equal parts. offsets calculated from this equation.

* By Successive Bisection of Arcs of chords :-

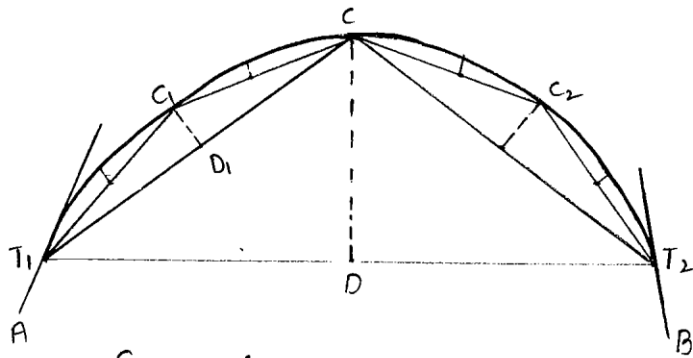

Successive Bisection of arcs

* Join the tangent point T_1, T_2 and bisect the long chord at D . Erect the perpendicular DC and make it equal to the versed sine of the curve. Thus,

$$CD = R \left(1 - \cos \frac{\Delta}{4} \right)$$

$$= R - \sqrt{R^2 - \left(\frac{L}{2} \right)^2}$$

* Join T_1C and T_2C and bisect them at D_1 and D_2 respectively. At D_1 and D_2 , set out perpendicular offsets $c_1D_1 = c_2D_2 = R \left(1 - \cos \frac{\Delta}{4} \right)$, to get points C_1 and C_2 on the curve.

* By the successive bisection of these chords, more points may be obtained.

* By Offsets from the tangents :- The offsets from the tangents can be of two types :- (i) Radial offsets (ii) perpendicular offsets.

* Radial offsets :-

let $O_x =$ Radial offset DE at any distance ' x ' along the tangent.

$$T_1D = x$$

from ΔT_1DO ,

$$DO^2 = T_1O^2 + T_1D^2$$

$$(DE + EO)^2 = T_1O^2 + T_1D^2$$

$$(O_x + R)^2 = R^2 + x^2$$

$$O_x = \sqrt{R^2 + x^2} - R \text{ for exact.}$$

approximate expression for O_x

expand $\sqrt{R^2+x^2}$, Thus,

$$O_x = R \left(1 + \frac{x^2}{2R^2} - \frac{x^4}{8R^4} + \dots \right) - R.$$

Now, neglect the other two except the first two, we get,

$$O_x = R + \frac{x^2}{2R} - R$$

$$O_x = \frac{x^2}{2R} \dots \text{(approximate).}$$

then,

$$T_1 D^2 = DE(2R + DE)$$

$$x^2 = O_x(2R + O_x)$$

Neglecting O_x in comparison to $2R$, we get

$$O_x = \frac{x^2}{2R} \text{ (app).}$$

ii) perpendicular offsets:-

let $DE = O_x =$ offsets perpendicular to the tangent.

$T_1 D = x$; measured along the tangent

Draw EE_1 parallel to the tangent.

A^{le} $EE_1 O$, we have.

$$E_1 O^2 = EO^2 - E_1 E^2.$$

$$(T_1 O - T_1 E_1)^2 = EO^2 - E_1 E^2.$$

$$(R - O_x)^2 = R^2 - x^2.$$

From which, $O_x = R - \sqrt{R^2 - x^2}$ (exact).

approximate expression for O_x .

expanding the term $\sqrt{R^2 - x^2}$, Thus,

$$O_x = R - R \left(1 - \frac{x^2}{2R^2} - \frac{x^4}{8R^4} \dots \right)$$

$$O_x = R - R + \frac{x^2}{2R}$$

$$O_x = \frac{x^2}{2R}$$

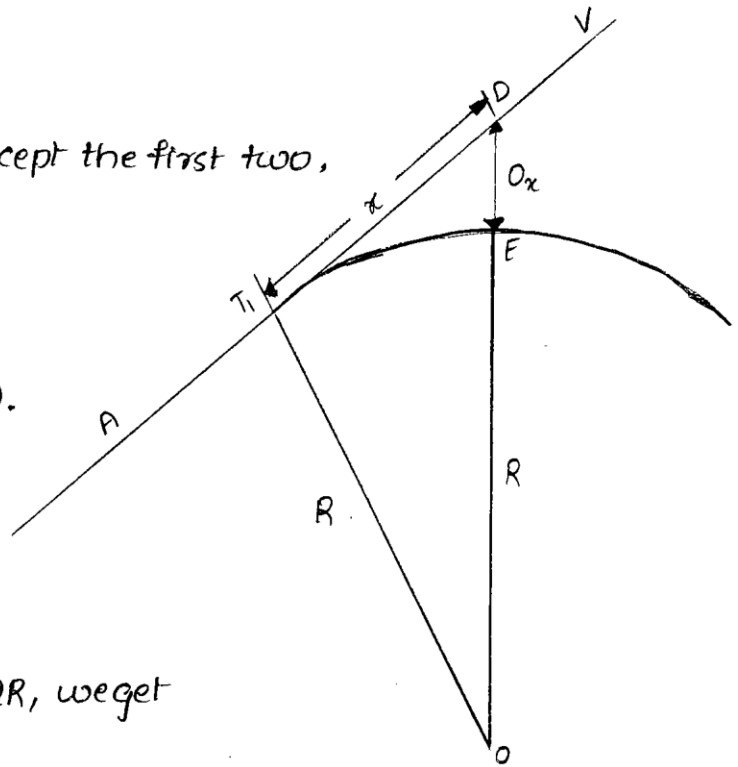

Setting out by Radial offsets.

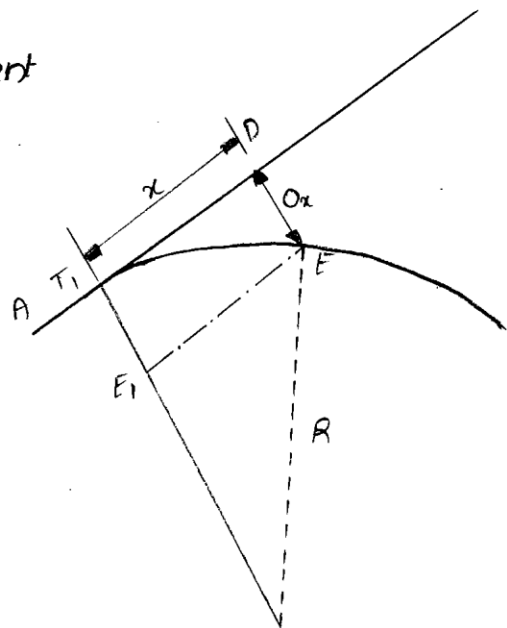

Setting out by perpendicular offsets.

* By deflection distances (or) Offsets from the chords produced:-

The method is very much useful for long curves and is generally used on highway curves when a theodolite is not available.

Let $T_1A_1 = T_1A =$ initial sub-chord
 $= C_1$

A_1B_1, C_1 etc. = points on the curve

$AB = C_2$

$BD = C_3$ etc.

$T_1V =$ Rear Tangent

$\angle A_1T_1A = \delta =$ deflection angle of the first chord.

$A_1A = O_1 =$ first offset.

$B_2B = O_2 =$ Second offset.

$D_2D = O_3 =$ Third offset, etc.

Now arc $A_1A = O_1 = T_1A \cdot \delta \rightarrow (i)$

Since T_1V is the tangent to the circle at T_1

$$\angle T_1OA = 2 \angle A_1T_1A = 2\delta$$

$$T_1A = R \cdot 2\delta$$

$$\delta = \frac{T_1A}{2R}$$

Sub in eq (i) value of δ , we get,

$$\text{Arc } A_1A = O_1 = T_1A \cdot \frac{T_1A}{2R} = \frac{T_1A^2}{2R}$$

Taking arc $T_1A =$ chord T_1A , we get,

$$O_1 = \frac{C_1^2}{2R}$$

The offset B_2B from the tangent A_1B_1 is given by

$$B_2B = \frac{C_2^2}{2R}$$

Again, $\angle B_2AB_1 = \angle A_1A_1T_1$, being opposite angles.

Since, T_1A' and $A'A$ are both tangents, they are equal in length

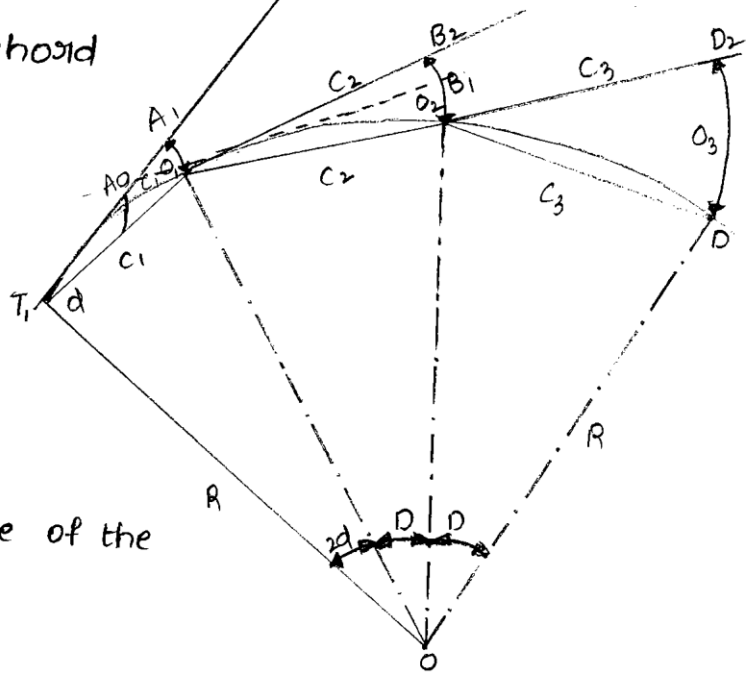

$$|A'T_1A| = S = |A'AT_1|$$

$$|B_2AB_1| = |A'AT_1| = S$$

$$\text{arc } B_2B_1 = AB_2 \cdot S = C_2 \cdot S$$

Sub the value of S from (ii), we get,

$$B_2B_1 = C_2 \cdot \frac{T_1A}{2R} = \frac{C_2 \cdot C_1}{2R}$$

$$\text{arc } B_2B = B_2B_1 + B_1B. \quad \Rightarrow O_2 = \frac{C_2 C_1}{2R} + \frac{C_2^2}{2R} = \frac{C_2}{2R} (C_1 + C_2)$$

Similarly, The n th offset $O_3 = D_2D$ is given by

$$O_3 = \frac{C_3}{2R} (C_2 + C_3)$$

Last or n th offset is given by

$$O_n = \frac{C_n}{2R} (C_{n-1} + C_n).$$

Generally, the first chord is a sub-chord. length c , and the intermediate chords are normal chords, length c , In that case, the above formulae reduce to

$$O_1 = \frac{c^2}{R}$$

$$O_2 = \frac{c}{2R} (c + c)$$

$$O_3 = O_4 = \dots O_{n-1} = \frac{c}{2R} (2c) = \frac{c^2}{R}$$

$$O_n = \frac{c'}{2R} (c + c')$$

where ' c ' is the last sub-chord.

"Instrumental methods:-

The following are instrumental methods commonly used for setting out a circular curve:

- (1) Rankine's method of tangential (or) deflection angle.
- (2) Two theodolite method.
- (3) Tacheometric method.

* Rankine's method:- A Deflection angle to any point on the curve is the angle at P_c between the back tangent and the chord from the P_c to that point.

The Rankine's method is based on the principle that the deflection angle to any point on the circular curve is measured by half of the angle subtended by the arc from point of curvature to that point.

It is assumed that the length of arc is approximately equal to its curve.

T_1, T_2 = A Rankie tangent.

T_c = point of curvature of given circular curve.

$\delta_1, \delta_2, \delta_3$ = The tangential angle (or) the angles which are present successive chord T_1A, AB & BC etc....

These are makes angle with the representative tangent to the curve at T_1, A, B .

$\Delta_1, \Delta_2, \Delta_3$ = These are the total tangential angles (or) deflection angles to the points A, B, C .

$\therefore C_1, C_2, C_3$ are the length of the chord.

$$T_1A = C_1$$

$$AB = C_2$$

$$BC = C_3 \text{ respectively.}$$

Finally, calculated deflection angle,

$$\delta_1 = 1718 \cdot a \frac{C_1}{R} \text{ min}$$

$$\delta_1 = \Delta_1$$

$$\Delta_2 = \delta_1 + \delta_2$$

$$\Delta_3 = \delta_1 + \delta_2 + \delta_3$$

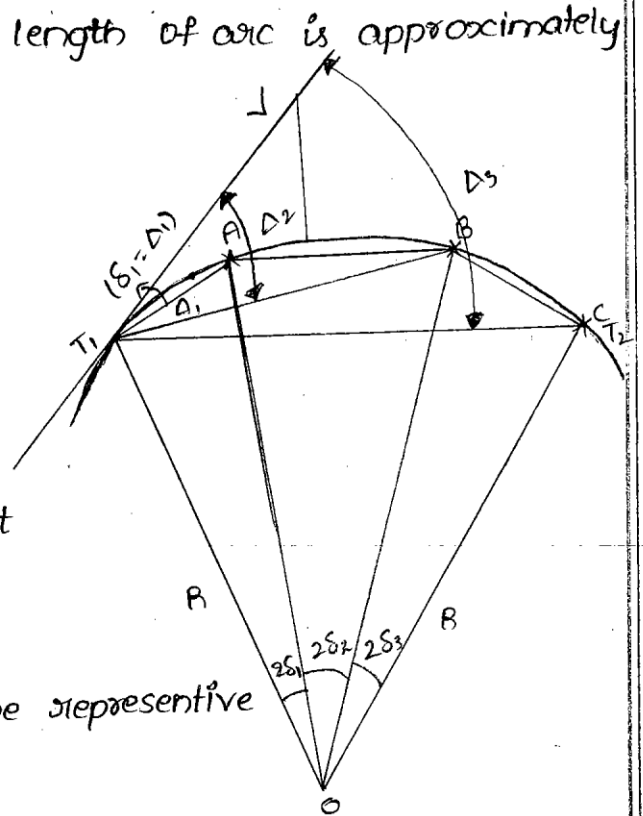

Two Theodolite method :-

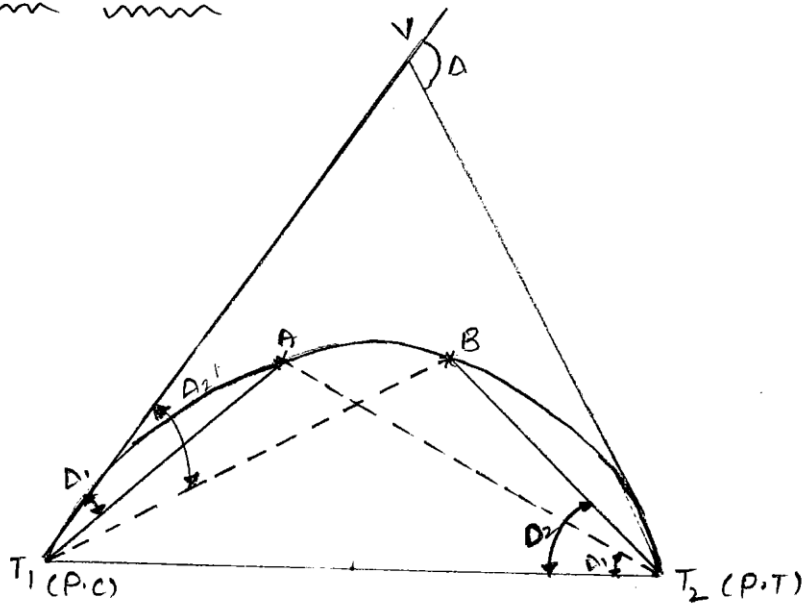

Two - Theodolite method.

* In this method two theodolites are used one at point of curve - ~~the~~ T_1 and another at P_T i.e., at T_2 the method is used when the ground is unsuitable for chaining and it is based on the principle of the angle between Tangent and the chord is equal to the angle which is the chords subtended in the opposite Segment.

$$\angle T_1 A = \Delta_1$$

i.e., Deflection angle for 'A' but $\angle A T_1 T_2$ is the angle subtended by the chord $T_1 A$ in the opposite segment

$$\therefore \angle A T_2 T_1 = \angle T_1 A = \Delta_1$$

Similarly $\angle B T_1 V = \angle T_1 T_2 B = \Delta_2$, Hence the angle between the long chord and the line - joining any point to T_2 is equal to the deflection angle to the point measured with the same tangent i.e., " Δ ".

* Tacheometric Method :-

Formulae :-

$$L = \frac{f}{i} S + (f+d), \text{ when the line of sight is horizontal}$$

$$L = \frac{f}{i} S \cos^2 \theta + (f+d) \cos \theta, \text{ when the line of sight is inclined.}$$

(Refer in text-book) (for more information).

Problems:-

1. Calculate the ordinates at 10m distances for a circular curve having a long chord of 80m and a versed sine of 4m.

Sol: The versed sine is given by,

$$O_0 = R - \sqrt{R^2 - \left(\frac{L}{2}\right)^2}$$

$$4 = R - \sqrt{R^2 - (40)^2}$$

$$R^2 - (40)^2 = (R - 4)^2 = R^2 + 16 - 8R$$

$$R = \frac{1616}{8} = 202 \text{ metres.}$$

$$(R - O_0) = 202 - 4 = 198 \text{ m.}$$

we have,

$$O_x = \sqrt{R^2 - x^2} - (R - O_0)$$

$$O_{10} = \sqrt{(202)^2 - (10)^2} - 198 = 201.75 - 198 = 3.75 \text{ m}$$

$$O_{20} = \sqrt{(202)^2 - (20)^2} - 198 = 201.01 - 198 = 3.01 \text{ m.}$$

$$O_{30} = \sqrt{(202)^2 - (30)^2} - 198 = 199.76 - 198 = 1.76 \text{ m}$$

$$O_{40} = \sqrt{(202)^2 - (40)^2} - 198 = 198 - 198 = 0.$$

2. Determine the offsets to be set out at $\frac{1}{2}$ chain interval along the tangents to locate a 16-chain curve, the length of each chain being 20m.

we have,

$$O_x = \sqrt{R^2 + x^2} - R \quad \text{Here } R = 16 \text{ chains.}$$

$$O_{0.5} = \sqrt{(16)^2 + (0.5)^2} - 16 = 0.0078 \times 20 \text{ chains} = 0.15625 \text{ mts}$$

$$O_1 = \sqrt{(16)^2 + (1)^2} - 16 = 0.031 \times 20 \text{ chains} = 0.62 \text{ m.}$$

$$O_{1.5} = \sqrt{(16)^2 + (1.5)^2} - 16 = 0.0702 \times 20 \text{ chains} = 1.40 \text{ mts.}$$

$$O_2 = \sqrt{(16)^2 + (2)^2} - 16 = 0.1245 \times 20 \text{ chains} = 2.49 \text{ mts.}$$

$$O_{2.5} = \sqrt{(16)^2 + (2.5)^2} - 16 = 0.1941 \times 20 \text{ chains} = 3.88 \text{ mts}^2$$

$$O_3 = \sqrt{(16)^2 + (3)^2} - 16 = 0.2788 \times 20 \text{ chains} = 5.58 \text{ mts.}$$

etc.